

# 2017 Deloupe

## Tri Axle Taper Frame Log Trailer

Stock #  
T2191



## SPECS

- 46' Long x 108" wide
- 4 tier
- Loader prep
- 11R 22.5 tires
- Aluminum wheels

# 2017 Deloupe

---



## Viking Taper Frame

### Dimensions

- Exterior 46' long X 108" wide
- 

### Suspension

- RIDEWELL 30K lb Air ride Tridem with
  - 25K axles .75" wall axles
  - Front axle 6.1" lift kit
- 

### Brakes

- Drum brakes
- 

### Coatings

- Epoxy basecoat topped with two coats of black polyurethane paint
- 

### Wheel Ends

- Parallel spindle bearings
- 

### Lighting & Wiring

- 2 LED Tail/Stop/Turn each side rear
- LED reverse lights
- Auxiliary Wire harness back to loader bay

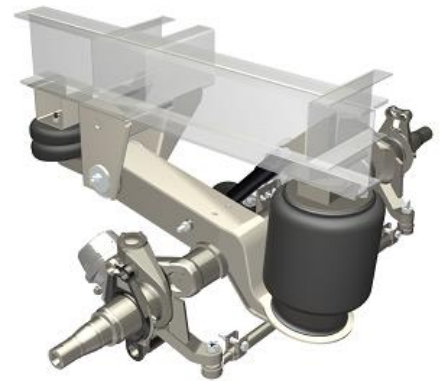

This liftable suspension is designed especially for the Canadian market and SPIF regulations, and is optimized for maximum up-travel for tire clearance. A lift kit comes standard with the unit. The suspension is rated for 30K lb capacity and comes with an air spring that will equalize with Ridewell's 30K lb capacity standard overslung RAR-260 or RAR-240 suspensions, without the need for a proportioning valve.

# 2017 Deloupe



## Viking Taper Frame

### Tires & Rims

- 12-DUNLOP 11R22.5 16 Ply Tires
- 12- 22.5" aluminum wheels

### Understructure

- 2 position removable Kingpin 24" 30"
- Holland Mark V Landing gear

### Other Features

- 4 tier loading configuration with self loader bay
- 8-winchers and 8-stainless steel load cables
- 8-Galvanized Viking log stakes

Innovations	Advantages
Galvanized stakes	Lightweight, maneuverability, durability
1/8 T1 steel floor	Reduced weight, enhanced solidity
Drops after 1 <sup>st</sup> anchor point	Optimized payload



Dunlop Features include:

- **Deep lug block tread design**—for drive position
- **Precision-angled tread elements**—helps provide superb traction, low noise, and even wear.
- **Tie bar reinforced shoulder**—helps promote even wear and enhanced performance in both single and twin-screw operations.



### HOLLAND MARK V Series



Sets the standard for strength, durability, and ease of lift.  
LIFT CAPACITY: 62,500 lbs. at 100 ft.-lbs. input torque  
ULTIMATE LOAD CAPACITY: 200,000 lbs.  
SIDE-LOAD CAPACITY: 32,000 lbs.  
GEAR RATIOS vs. TURNS PER INCH:  
Low Gear = 33.8, High Gear = 2.5



### Get in touch

Bill Tait  
Trailer Sales Manager  
902.698.3993  
btait@novatrucks.ca